

Specifications

The Velvet Drive Marine Series 5000V is the latest member of the Velvet Drive transmission family. The Series 5000V is designed specifically for v-drive applications. Its fully reversing feature allows for a twin-engine layout using “automotive” rotating engines, while the 12 degree down angle between the input and output shafts allows the desired system installation. The coupling flange, located on the opposite side to the

engine and hollow output shaft, provides position and ease of propeller shaft alignment. The compact design and aluminum case provide a lighter and considerably shorter package than the 70 Series v-drive. The improved hydraulic system, with reduced parasitic losses, offers more power to the propeller. The Series 5000V has the same engine adaptation features as the 70 Series and Series 5000 down angle.

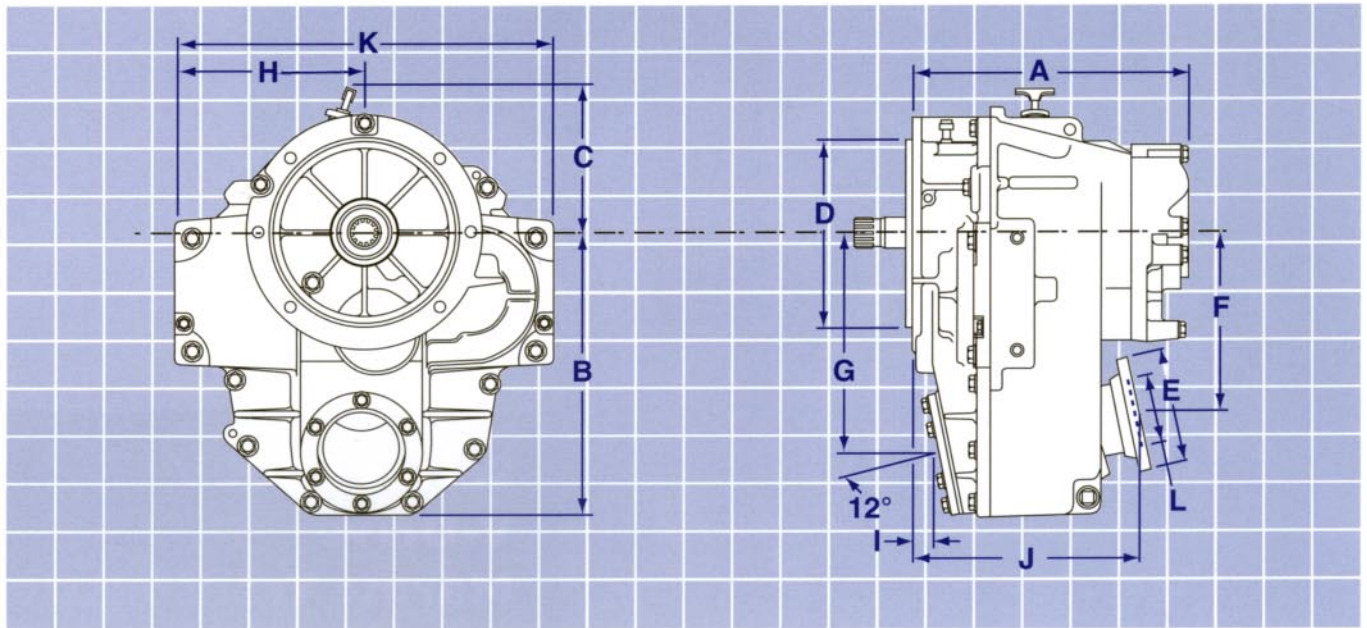

Dimensions Inches (millimeters)

A	B	C	D	E	F	G	H	I	J	K	L
12.10 (307)	12.40 (316)	6.37 (161.8)	8.25 (209.55)	5.00 (127)	7.90 (200)	9.80 (248)	8.23 (209)	1.10 (28)	10.0 (254)	16.46 (418)	2.50 (63.50)

General Information (subject to change without notice)

Available Ratios 1.25, 1.50, 2.00, 2.50:1
Input Shaft Spline Teeth 26
Input Shaft Rotation automotive
Output Shaft Rotation either direction
Approximate Dry Weight 133 lbs. (60.4 kg)

Hollow output shaft to accept 2" (51.0mm) diameter through shaft